



Air Technology

Reducing energy and noise;
both effectively and economically

Contents:

Meech Air Technology **3**

UK manufacturer of compressed air products that save energy, reduce noise levels and cool efficiently. Technical support is provided by our worldwide distributor network.



Energy Saving **4**

Squeezing the cost of compressed air – almost 90% of the UK manufacturing industry uses compressed air. Learn how Meech saves its clients thousands of pounds each year.



Sound Levels & Safety **5**

Your safety - our first concern. Don't become a long term victim of high noise levels; many Meech products dramatically lower noise levels to improve the working environment.



Energy Saving Safety Nozzle **6-7**

Energy Saving Safety Nozzles from Meech Air Technology can save up to 70% of compressed air demand whilst dramatically reducing noise levels.



Energy Saving Safety Blowgun **8-9**

Energy Saving Safety Blowguns from Meech Air Technology combine an ergonomic lightweight gun handle with the Meech Nozzle. Meech Blowguns typically save up to 70% of compressed air usage and reduce noise levels.



High Thrust Jet **10-11**

Meech Air Technology High Thrust Jets are designed to provide a high power blast of air whilst reducing compressor demand and lowering noise levels.



Air Amplifier/Mover **12-13**

Meech Air Technology Air Amplifiers provide large airflows whilst consuming a minimal volume of compressed air. The Air Amplifiers are available in three sizes and in either aluminium or stainless steel.



SpeedDri **14-15**

The SpeedDri system is an in-booth drying system that will fit any spraybooth and considerably reduce the drying time on any waterborne paint job.



Air Curtain/Knife **16-17**

The Air Curtain from Meech Air Technology provides an efficient blade of air for wide area blow-off and drying applications. The Air Curtain offers compressed air savings of up to 70%.



Vortex Tube **18-19**

Meech Air Technology Stainless Steel Vortex Tubes convert compressed air into two airflows, one extremely cold and the other extremely hot.



Cabinet Cooling System **20-21**

Meech Air Technology Stainless Steel Cabinet Cooler Systems provide a cool air source to stop cabinets overheating and prevent ingress of contamination such as dust or moisture. They provide the ideal cooling solution.



Coldstream Air Gun **22-23**

Coldstream Air Guns from Meech Air Technology provide a cold airflow that is commonly used for spot cooling. The cold airflow can be up to a 50°C drop from compressed air temperature and be maintained to +/- 0.6°C.

NOTE:

- All Meech products require appropriate filters.
- All Meech products are tested at factory settings.
- Sound level readings are taken at 1000mm distance.
- Thrust levels are recorded at 200mm from target.



Meech Air Technology has developed a distribution network of companies with offices around the world to ensure that our customers receive the level of service and response that only a local resource can provide. Distributors are selected for their knowledge of the pneumatic/compressed air industry and their ability to deliver a full-service offering to their local customer base, capitalising on their technical service and capability, stock holding, speed of service and knowledge of the products and the local market.



Meech HQ - Witney, Oxfordshire

All our distributors are fully conversant with the application, operation and installation of Meech Air Technology products so that they are quickly able to propose the correct solution for each particular situation and understand how it will be integrated into the production environment.

Meech Air Technology ensures that its distributors receive frequent update training and supporting information regarding new products and enhancements to the existing product line, as well as having rapid access to our experts based in Witney, UK.





The chilling cost of Compressed Air

Compressed air is vital to a huge range of industrial applications, whether it is blowing dust from routing machines, drying glass bottles or blowing crisp packets off conveyor lines. In fact, almost 90% of the UK manufacturing industry uses compressed air in some part of its production process. However, the true cost of compressed air is often forgotten, simply because it is so convenient.

Free as air

Because the air we breathe is free, it's all too easy to consider compressed air in the same way. But of course, compressed air is far from free, as anyone considering buying a new compressor knows only too well. Most companies today have energy saving policies but all too often the efficient use of compressed air simply isn't considered - which can be a costly omission.

Legislation

For companies across the UK, the cost of the Climate Change Levy (CCL) legislation is a reality. The good news is that it's not too late to do something to alleviate these charges. In fact, there has never been a better time to act, as developments in technology mean that even more efficient solutions are available to

save compressed air, save energy, save waste and save money. The CCL is a fact of manufacturing life, and whatever may subsequently be decided in Westminster or Brussels in these highly competitive times, energy saving is not only good for the environment, it is good for the bottom line too.

How can Meech help?

By harnessing the forces of physics, Meech develops products that increase the efficiency of the compressed air delivered to the

point of application, simultaneously reducing total energy consumption and increasing standards of operator comfort. Sounds too good to be true? Well, read on...

Energy Saving

To take one example, the installation of Meech Nozzles can immediately reduce compressed air consumption by an average of 70% (and increase output by up to 25 times). So perhaps you don't need that new compressor after all? Not only will you achieve increased air output, but compressor wear is reduced as well, extending the life of the compressor still further. It really is as easy as it sounds. By cleverly using scientific principles in the design of the Air Saver Nozzle, Meech saves its clients many thousands of pounds each year.

Did you know?

A typical manufacturing company spends about 10% of its electricity bill on producing compressed air.

(Source: British Compressed Air Society)



Your safety - our first concern

Meech Air Technology products are safe for your workforce. Compressed air is a powerful source of energy and just because you can't see it doesn't mean it can't harm you. At Meech we ensure that all our products are designed and manufactured to the highest standard to obviate any risk to end-users.

"It shall be the duty of every employer to ensure, so far as is reasonably practicable, the health, safety and welfare at work of all his employees."

Health and Safety at Work Act 1974 – Chapter 37, Section 2

"In selecting work equipment, every employer shall have regard to the working conditions and to the risks to the health and safety of persons which exist in the premises or undertaking in which that work equipment is to be used and any additional risk posed by the use of that work equipment"

Provision and Use of Work Equipment Regulations 1998

Noise - a health hazard

Noise is both unwanted and potentially damaging. In the manufacturing environment, noise is usually generated by machinery, tools and compressed air. In fact recent analysis has shown that almost 80% of all hearing loss suffered within manufacturing industry is the result of noise generated by the use of compressed air.

Over-exposure to noise damages the sensitive structures of the inner ear, causing noise-induced hearing loss. Noise-induced hearing loss is cumulative and permanent. Historically people accepted noisy workplaces as an inescapable fact of life. This is no longer true; employees now demand good working conditions, legislation supports them and good employers comply willingly. The most effective and economical solution to noise pollution is abatement at source and Meech equipment is specifically designed to reduce noise whilst at the same time reducing compressed air consumption - a win-win situation.

Quite often air guns can be the decisive factor in meeting the Economic Union's Machine Directive limits for maximum daily exposure to noise.

Industrial deafness affects thousands of people every year and the consequences are devastating for both work and family life. A Medical Research Council (MRC) survey in 1997-98 gave a national prevalence estimate of 509,000 persons in Great Britain suffering from hearing difficulties as a result of exposure to noise at work.

"Machines shall be designed and constructed so that the risks associated with the emission of airborne noise are reduced to the lowest level possible with consideration to technological advances and existing devices designed to reduce noise, particularly at its source."

EU Machine Directive

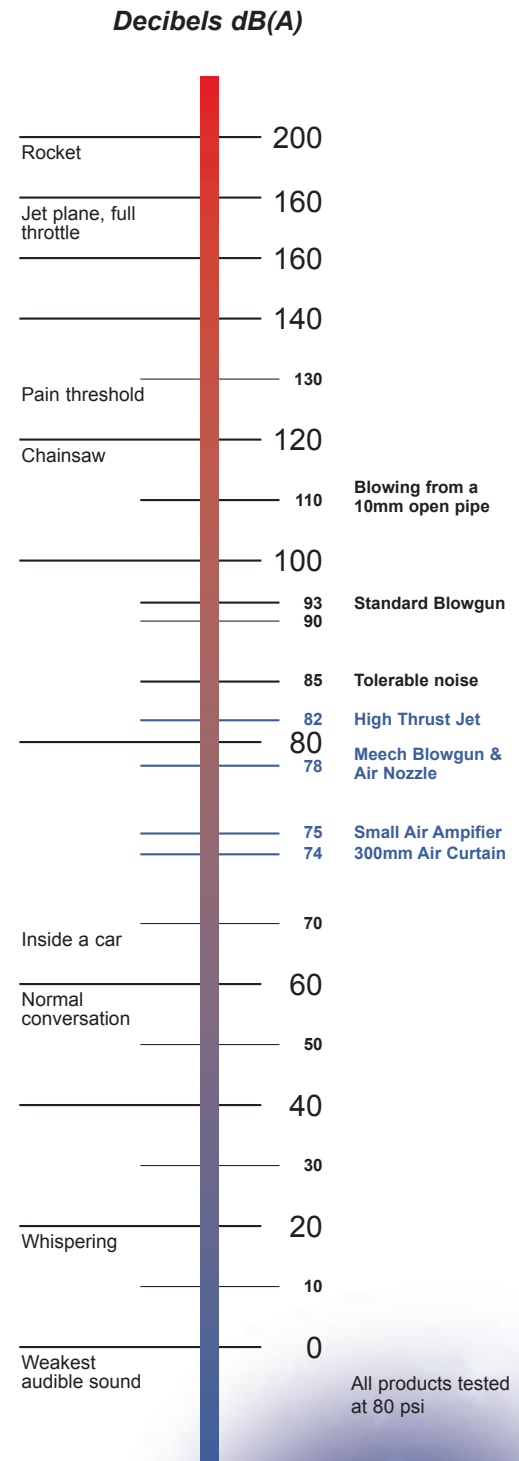



Energy Saving Safety Nozzle

Energy Saving Safety Nozzles from Meech Air Technology can save up to 70% of compressed air demand whilst dramatically reducing noise levels.

APPLICATIONS:

- *Air saving: reduction of energy bills*
- *Compressor demand reduction*
- *Noise reduction*
- *Parts ejection*
- *Swarf removal*
- *Cooling of parts*

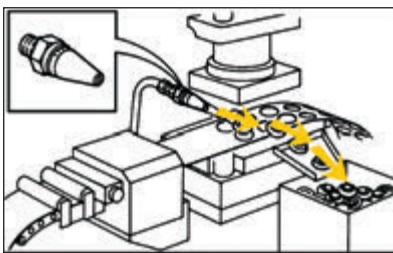

Parts Ejection

It requires high thrust to eject parts quickly from this stamping press. The adjustable output of the Model A48009 Nozzle can be set to do the job efficiently and quietly whilst also conserving compressed air.

DIMENSIONS:

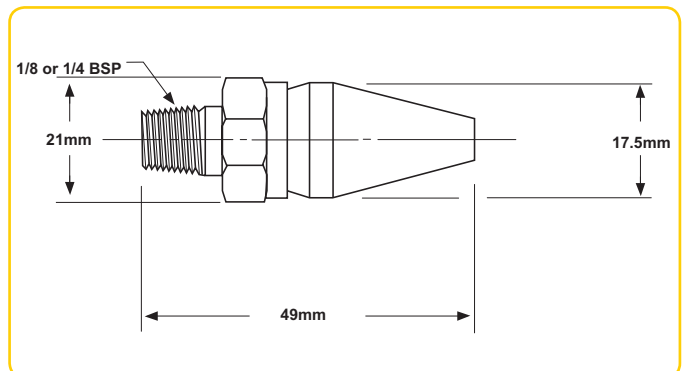

How it works:

The innovative nozzle design forces compressed air through an adjustable circular slot and then directs it at high velocity on to the outside of the nozzle cone (no air exits the hole at the end of the nozzle; a simple lock screw is located here for slot adjustment). This design amplifies the output airflow by entraining ambient air at a 25:1 ratio and is compliant with health and safety requirements.

FEATURES AND BENEFITS:

- | | |
|-------------------|-------------------------------|
| Innovative design | - 25:1 air amplification |
| | - Up to 50dBA noise reduction |
| | - Health and Safety compliant |
| No moving parts | - Low maintenance |
| Adjustability | - Application specific set-up |

PRODUCT NUMBERS AND DESCRIPTIONS:

- | | | |
|------------|---|---|
| A48009-1/8 | - | Aluminium Energy Saving Nozzles, 1/8" bsp, 5 pack |
| A48009-1/4 | - | Aluminium Energy Saving Nozzles, 1/4" bsp, 5 pack |
| A40009-1/8 | - | Stainless Steel Energy Saving Nozzles, 1/8" bsp, 5 pack |
| A40009-1/4 | - | Stainless Steel Energy Saving Nozzles, 1/4" bsp, 5 pack |



MEECH NOZZLE:

Inlet Air Pressure		Air Consumption		Sound Level	Thrust Level
psi	bar	cfm	lpm	dBa	Grams
20	1.4	8	227	66	60
40	2.7	11	312	72	130
60	4.1	13	368	76	202
80	5.4	15	425	78	285
100	6.8	17	473	80	335

OPEN PIPES:

Inlet Air Pressure		Air Consumption			
		1/8"		1/4"	
psi	bar	cfm	lpm	cfm	lpm
20	1.4	12	340	47	1331
40	2.7	16	453	66	1869
60	4.1	20	566	81	2294
80	5.4	23	651	93	2634
100	6.8	26	736	104	2945

PERFORMANCE GRAPH:

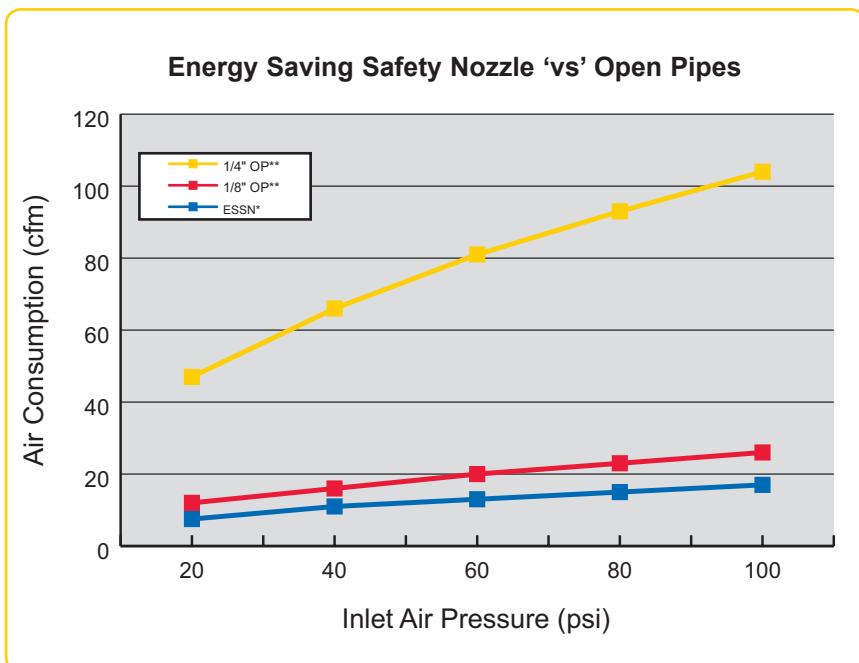

Energy Saving Example

Company 'A' uses 5 x 1/4" open air pipes running at 80psi inlet air pressure to keep a motor cool by blowing air over it. The open air pipes run constantly for 16 hours per day, 5 days per week, 48 weeks per year. Company 'A' has an electricity cost of 5p/kWhr.

Each 1/4" open air pipe has an air consumption of 93cfm, giving a total consumption of 465cfm (5x93).

By installing Meech Nozzles, dramatic air and cost savings can be made. When running at 80psi inlet air pressure each Meech Nozzle has an air consumption of 15cfm, giving a total consumption of 75cfm (5x15), less than 1 x 1/4" open pipe!

RUNNING COST COMPARISON:

Duration	1xESSN*	1xOP**	5xESSN	5xOP
Per Day	£2.25	£13.95	£11.25	£69.75
Per Week	£11.25	£69.75	£56.25	£348.75
Per Year	£540	£3,348	£2,700	£16,740

* ESSN - Energy Saving Safety Nozzle
 ** OP - Open Pipe

This shows that a massive 84% saving in annual running costs (equivalent to £16,740 - £2,700 = £14,040) can be achieved by installing 5 Meech Nozzles.





Energy Saving Safety Blowgun

Energy Saving Safety Blowguns from Meech Air Technology combine an ergonomic lightweight gun handle with the Meech Nozzle (see page 6). Meech blowguns typically save up to 70% of compressed air usage compared to conventional types of blowgun whilst dramatically reducing noise levels.

APPLICATIONS:

- *Air saving: reduction of energy bills*
- *Compressor demand reduction*
- *Noise reduction*
- *Swarf removal*
- *Any Blowgun task*

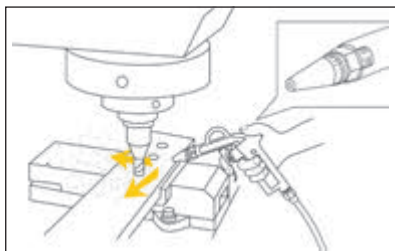

Drilling - Swarf Removal

The 25:1 air amplification of the Meech Blowgun provides plenty of cleaning power whilst lowering air consumption and noise levels.

DIMENSIONS:

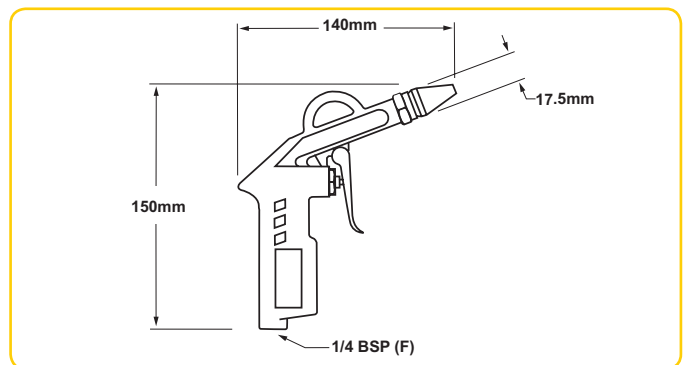

How it works:

The innovative nozzle design forces compressed air through an adjustable shim and then directs it at high velocity on to the outside of the nozzle cone (no air exits the hole at the end of the nozzle; a simple lock screw is located here for shim adjustment). This design amplifies the output airflow by entraining ambient air at a ratio of 25:1 and is compliant with health and safety requirements.

FEATURES AND BENEFITS:

- | | |
|-------------------|-------------------------------|
| Innovative design | - 25:1 air amplification |
| | - Up to 50dBA noise reduction |
| | - Health and Safety compliant |
| No moving parts | - Low maintenance |
| Adjustability | - Application specific set-up |
| Ergonomic handle | - Operator comfort |

PRODUCT NUMBERS AND DESCRIPTIONS:

A45400	-	Energy Saving Safety Blowgun, Aluminium Nozzle (Silver)
A45400SS	-	Energy Saving Safety Blowgun, Stainless Steel Nozzle (Silver)
A45401	-	Energy Saving Safety Blowgun, Aluminium Nozzle (Black)
A45401SS	-	Energy Saving Safety Blowgun, Stainless Steel Nozzle (Black)



MEECH BLOWGUN:

Inlet Air Pressure		Air Consumption		Sound Level
psi	bar	cfm	lpm	dBa
20	1.4	8	227	66
40	2.7	11	312	72
60	4.1	13	368	76
80	5.4	15	425	78
100	6.8	17	481	80

STANDARD BLOWGUN:

Inlet Air Pressure		Air Consumption		Sound Level
psi	bar	cfm	lpm	dBa
20	1.4	9	255	75
40	2.7	14	396	83
60	4.1	18	510	90
80	5.4	22	623	93
100	6.8	25	708	95

PERFORMANCE GRAPH:

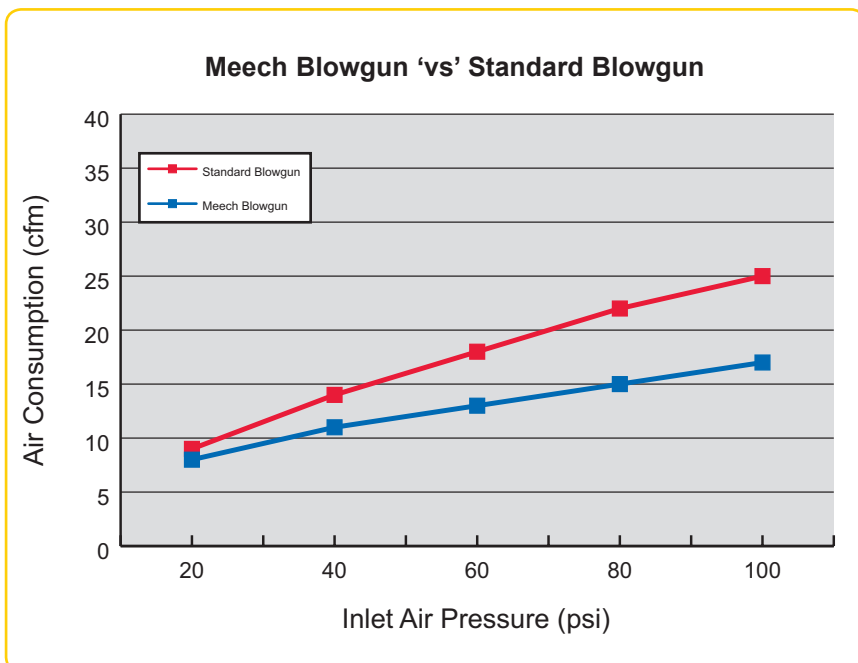

Energy Saving Example

Company 'B' uses 50 standard blowguns at 80psi inlet air pressure to blow swarf from machined parts. Each part takes approximately 1 minute to clean and each operator cleans 450 parts per day. Company 'B' works 5 days per week, 48 weeks per year and has an electricity cost of 5p/kWhr.

Each standard blowgun consumes 22cfm and costs £1.55 per day to run, giving a total cost of £77.50 per day.

By installing Meech Blowguns dramatic cost savings can be made. When running at 80psi inlet air pressure, each Meech Blowgun consumes 15cfm and costs £1.05 per day to run, giving a total cost of £52.50 per day.

RUNNING COST COMPARISON:

Duration	1xMBG*	1xSBG**	50xMBG	50xSBG
Per Day	£1.05	£1.55	£52.50	£77.50
Per Week	£5.27	£7.73	£263.50	£386.50
Per Year	£253	£371	£12,656	£18,562

* MBG - Meech Blowgun
** SBG - Standard Blowgun

Investment in 50 Meech Blowguns costs less than £1,000 and gives Company 'B' an annual saving of £5,906 (£18,562 - £12,656), equivalent to 32%.

The workforce of Company 'B' also benefits from a substantial drop in noise levels. A standard blowgun running at 80psi inlet air pressure has a noise level of 93dBA, 8dBA above the 85dBA tolerable noise level. By comparison a Meech Blowgun has a noise level of 78dBA.





Energy Saving High Thrust Jet

Meech Air Technology High Thrust Jets are designed to provide a high power blast of air whilst reducing compressor demand and lowering noise levels.

APPLICATIONS:

- Air saving: reduction of energy bills
- Compressor demand reduction
- Noise reduction
- Swarf removal
- Material conveying
- Product drying



Food Processing

The Model A38038 High Thrust Jets remove water and dry cans in this soup processing plant. The adjustable thrust feature produces maximum drying to ensure peak line speed.

DIMENSIONS:

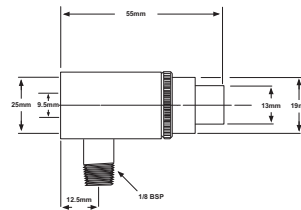

High Thrust Jet
Model 38038

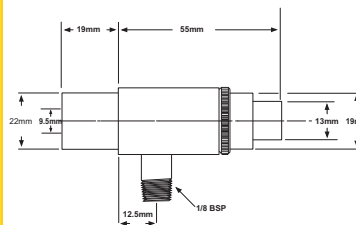

Inline High Thrust Jet
Model 38044

How they work:

High Thrust Jets use a very small amount of compressed air to generate a high power blow off force. This is achieved by forcing compressed air through an adjustable internal circular slot. The high velocity air from the slot generates an area of low pressure at the rear of the jet that entrains ambient air at a ratio of 4:1. This maximises the high power blow off force whilst complying with health and safety requirements.

FEATURES AND BENEFITS:

- | | |
|-------------------|-------------------------------|
| Innovative design | - 4:1 air amplification |
| | - Up to 50dBA noise reduction |
| | - Health and Safety Compliant |
| No moving parts | - Low maintenance |
| Adjustability | - Application specific set-up |
| Energy saving | - Cuts compressed air usage |

PRODUCT NUMBERS AND DESCRIPTIONS:

A38038	-	High Thrust Jet, Brass
A38038SS	-	High Thrust Jet, Stainless Steel
A38044	-	In-Line High Thrust Jet, Brass



MEECH HIGH THRUST JET:

Inlet Air Pressure		Air Consumption		Sound Level	Thrust Level
psi	bar	cfm	lpm	dBa	Grams
20	1.4	13	368	76	85
40	2.7	18	510	80	212
60	4.1	22	623	82	334
80	5.4	26	736	85	467
100	6.8	29	821	86	628

Energy Saving Example

Company 'C' uses two 1/4" open pipes on its check weighing station to eject products of the incorrect weight. Each time a product is ejected the open pipes blast for 60 seconds at 80psi inlet air pressure. Company 'C' operates for 5 days per week, 48 weeks per year and has two 8 hour shifts per day. On average each open pipe blasts 40 times per 8 hours. The electricity cost for Company 'C' is 5p/kWhr.

Each 1/4" open pipe consumes 93cfm at 80psi inlet air pressure.

Retrofitting Meech High Thrust Jets to each open pipe reduces the air consumption from 93cfm to 26cfm (a 73% saving).

1/4" OPEN PIPE

Inlet Air Pressure		Air Consumption		Sound Level	Thrust Level
psi	bar	cfm	lpm	dBa	Grams
20	1.4	47	1331	73	212
40	2.7	66	1869	84	477
60	4.1	81	2294	90	795
80	5.4	93	2634	94	1094
100	6.8	104	2945	97	1221

RUNNING COST COMPARISON:

Duration	2 x HTJ*	2 x 1/4" OP**
Per Day	£0.64	£2.32
Per Week	£3.20	£11.60
Per Year	£154	£557

* HTJ - High Thrust Jet
** OP - Open Pipe

Company 'C' would make an annual saving of approximately £403 (£557 - £154) or 73%. This saving is sufficient to purchase both of the Meech High Thrust Jets more than 4 times over.

PERFORMANCE GRAPH:

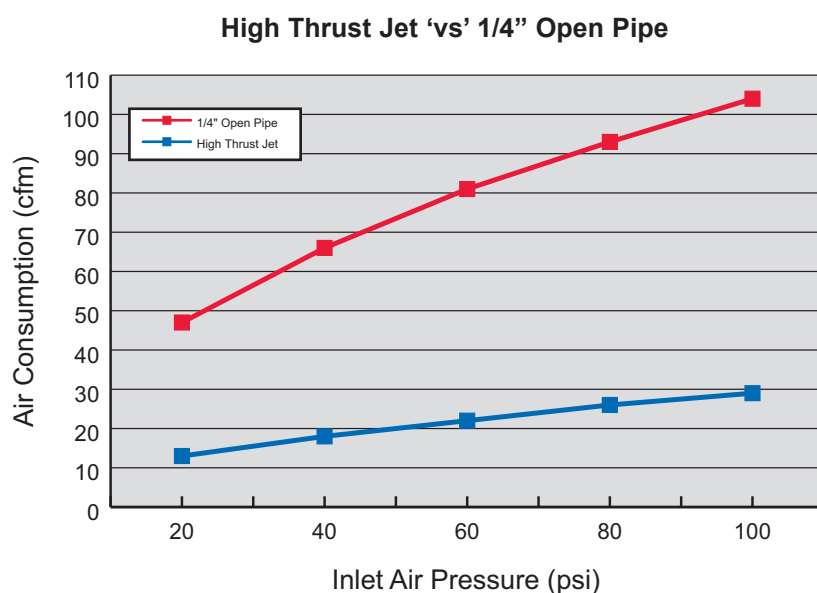



Energy Saving Air Amplifier

Meech Air Technology Air Amplifiers provide large airflows whilst consuming a minimal volume of compressed air. The Air Amplifiers are available in three sizes and in either aluminium or stainless steel.

APPLICATIONS:

- *Product redirection*
- *Product drying*
- *Air saving: reduction of energy bills*
- *Compressor demand reduction*
- *Noise reduction*
- *Product cooling*

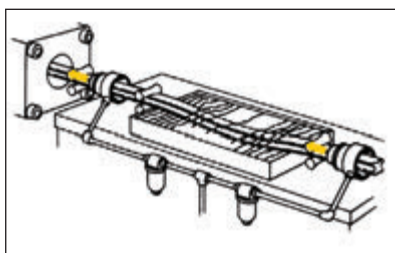

Extrusion - Rubber Moulding Cooling & Drying
Model A10015 Stainless Steel Air Amplifiers help set-up and cool this moulding after extrusion. They then blow off and dry the moulding prior to cutting.

DIMENSIONS:

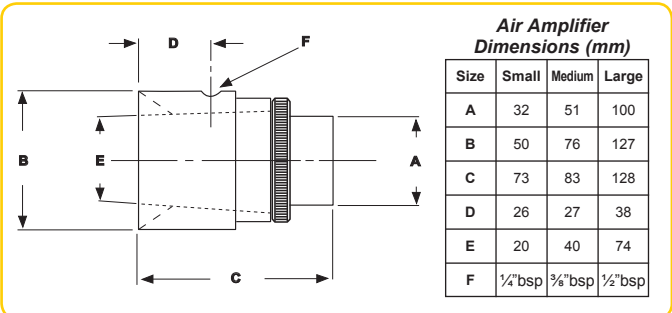

How they work:

A tiny amount of compressed air is released through an adjustable circular slot inside the Air Amplifier, creating a 'tube' of air. The tube of air then travels on the inside of the Air Amplifier towards the front creating areas of low pressure behind and in front, that entrain ambient air at ratios of 12, 20 and 25:1 (model dependant). Air Amplifiers are health and safety compliant.

FEATURES AND BENEFITS:

- | | |
|-------------------|--|
| Innovative design | - 12 to 25:1 air amplification |
| | - Up to 50dBA noise reduction |
| | - Health and Safety compliant |
| No moving parts | - Low maintenance |
| Adjustability | - Application specific set-up (no shims) |
| Locking ring | - Holds specific set-up |

PRODUCT NUMBERS AND DESCRIPTIONS:

A15008	-	Small Air Amplifier, Aluminium
A10008	-	Small Air Amplifier, Stainless Steel
A15015	-	Medium Air Amplifier, Aluminium
A10015	-	Medium Air Amplifier, Stainless Steel
A15030	-	Large Air Amplifier, Aluminium
A10030	-	Large Air Amplifier, Stainless Steel



MEECH AIR AMPLIFIERS:

Inlet Air Pressure		size	Air Consumption		Sound Level	Thrust Level
psi	bar		cfm	lpm	dBa	Grams
20	1.4	small	8	212	52	44
		medium	13	368	59	109
		large	15	425	58	113
40	2.7	small	11	300	62	114
		medium	18	510	70	258
		large	21	595	65	268
60	4.1	small	13	368	71	213
		medium	22	623	77	419
		large	26	736	70	455
80	5.4	small	15	425	75	308
		medium	25	708	79	601
		large	30	850	73	646
100	6.8	small	17	481	78	406
		medium	28	793	86	674
		large	34	963	76	747

PERFORMANCE GRAPH:

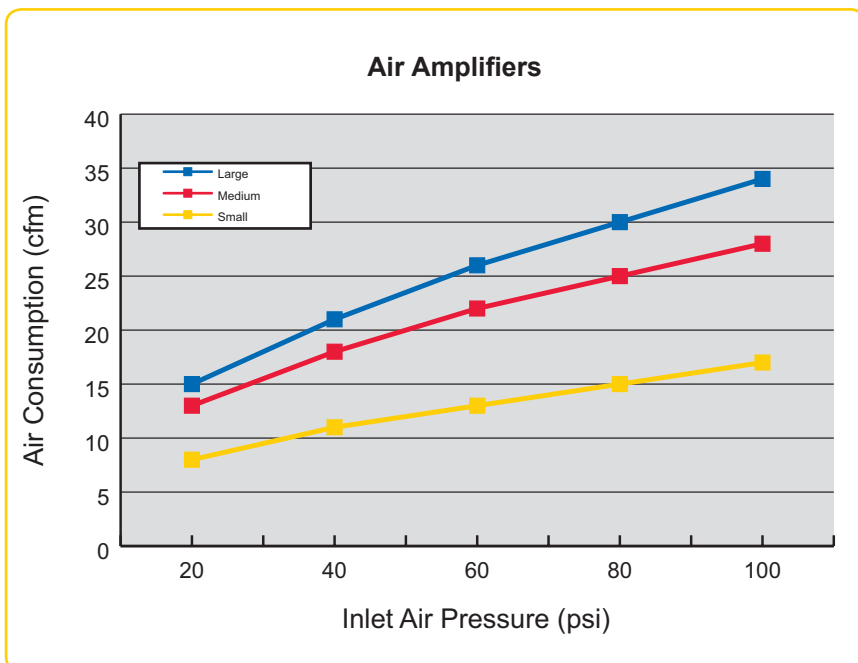

Energy Saving Example

Company 'D' uses 4 x 1/8" open pipes to dry rigid extrusion as it exits a water bath. The open pipes run constantly for 12 hours per day, 6 days per week and 48 weeks per year. Company 'D' has an electricity cost of 5p/kWhr.

The total air consumption of the open pipes is 92cfm at 80psi inlet air pressure.

By replacing the 4 open pipes with a single medium size Meech Air Amplifier, Company 'D' can dramatically save compressed air and also improve drying results as the extrusion is passed through the centre of the Air Amplifier.

The medium size Meech Air Amplifier has an air consumption of 25cfm at 80psi inlet air pressure (a reduction of 73%).

RUNNING COST COMPARISON:

Duration	1 x MAA*	4 x 1/8" OP**
Per Day	£2.81	£10.35
Per Week	£16.88	£62.10
Per Year	£810	£2,980

* MAA - Medium Air Amplifier

** OP - Open Pipe

The above table shows that an annual saving of £2,170 (£2,980 - £810), or 73% is achieved by changing to a Meech Air Amplifier.





SpeedDri

The SpeedDri system is an in-booth drying system that will fit any spraybooth and considerably reduce the drying time on any waterborne paint job.

APPLICATIONS:

- *Car refinishing*



The SpeedDri system retrofitted into an existing spray booth will speed up drying time on all waterborne paint jobs ultimately increasing productivity. The flexible system also allows for multiple drying jobs increasing throughput in the booth.

SYSTEM OVERVIEW:

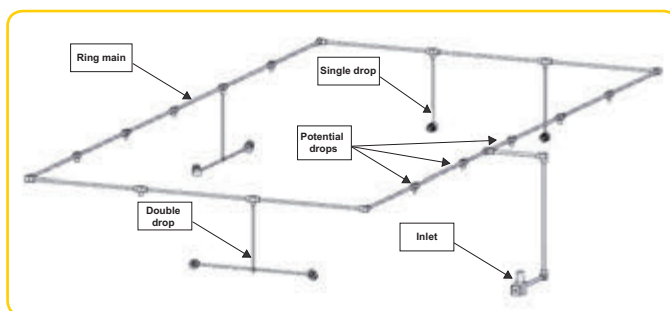

How it works:

The system includes 6 fully adjustable Air Amplifiers (see page 12). These are connected by interchangeable drop points to a ring main mounted above the ceiling and filters. The Air Amplifiers blow a direct stream of air over the surface of the basecoat thus speeding up the evaporation process.

FEATURES AND BENEFITS:

- | | |
|---|---|
| Push Fit Couplings | – Very simple installation reduces booth downtime |
| Fully adjustable and interchangeable drops | – Fits virtually any booth |
| Venturi air amplifier technology | – Allows the drying of any spray job |
| No moving parts | – Entrain ambient air resulting in lower compressed air consumption for a specific output |
| In plenum installation | – Requires little maintenance |
| Utilises the existing body shop compressed air supply | – Creates clutter free booth |
| Is positioned in the clean zone of the booth | – Avoids the risk of staff accidents |
| Additional drops and accessories available | – No need for additional air supply |
| | – No need to remove it between jobs |
| | – Can expand the system if necessary |

PRODUCT NUMBERS AND DESCRIPTIONS:

A15SDS

-

Complete SpeedDri System



AIR CONSUMPTION AND SPEED:

The graphs below show the Air Consumption and Air Speed at inlet pressures of 0.5 to 3.0 Bar at distances of 0.5 and 1.0m from the air outlet.

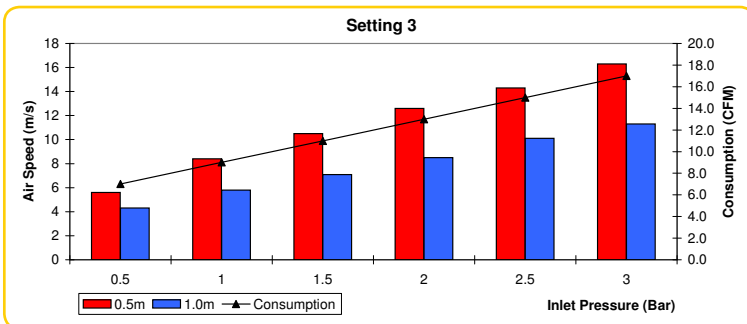
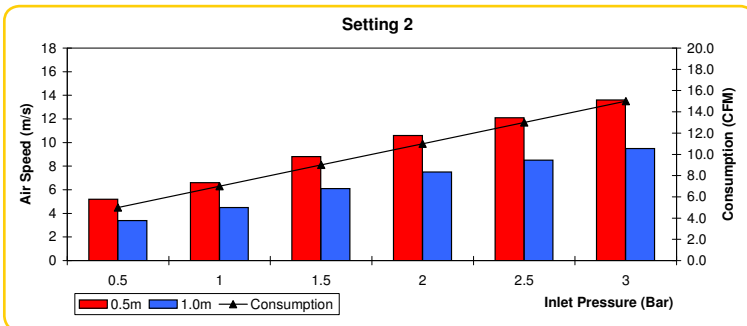
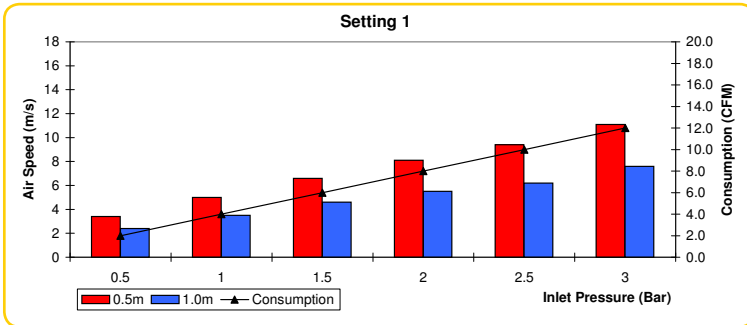

Adjustable Settings

The speed and volume of air at a given distance can be adjusted using either the input pressure or the flow adjuster on the air amplifier; alternatively a combination of the two can be used. The air amplifier supplied is marked with three different settings and calibrated to give a range of performance. These settings are assigned the numbers 1, 2 and 3 with setting 1 equating to the lowest consumption and slowest air speed (at a given distance), setting 3 equating to the greatest consumption and highest air speed (at a given distance) and setting 2 producing performance between the two.

A variable offered by the adjustability of the Air Amplifier and the inlet pressure is the spread of air produced by a single Air Amplifier. The coverage provided by the Air Amplifier for the three settings is shown in the diagram below:

Setting 1

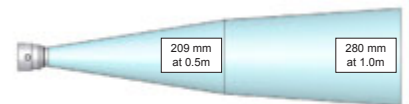

Setting 2

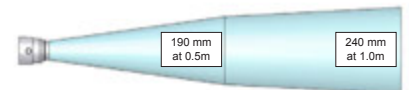

Setting 3



TECHNICAL SPECIFICATION & OVERVIEW:

The Meech SpeedDri system combines the practicality, performance and clutter free installation of much more expensive in-booth arrangements, with the versatility and cost comparable to that of hand-held solutions. By connecting to the existing compressed air supply of the spraybooth, via a ball valve and pressure regulator, a ring main is created above the ceiling and filters. Connected to this ring main are 14 bayonet couplings which are mounted through the ceiling for flexible system configuration.



The required inlet pressure will vary depending upon the arrangement of the drops, their distance from the relevant parts, and the required air speed and volume at the desired surface. Typically this is in the range of 0.5 to 2.0 Bar (approximately 7 to 29 psi) and in most instances pressures greater than this are not needed. The maximum inlet pressure must NOT exceed 4.1 Bar (60 psi). With all 6 Air Amplifiers connected, adjusted to setting 1 and running at the maximum suggested inlet pressure of 2.0 Bar (29 psi), the SpeedDri System will consume a total of approximately 48 cfm (1362 l/min). The push fit couplings allow the system to be assembled with minimal cutting and drilling. Installation of the SpeedDri System will take typically 4 hours for two people.





Energy Saving Air Curtain

The Air Curtain from Meech Air Technology provides an efficient blade of air for wide area blow-off and drying applications. When used to replace drilled or slotted lengths of pipe, which consume vast volumes of compressed air, the Air Curtain offers compressed air savings of up to 70%.

APPLICATIONS:

- *Product drying*
- *Product cooling*
- *Swarf contamination removal*
- *Air saving: reduction of energy bills*
- *Compressor demand reduction*
- *Noise reduction*

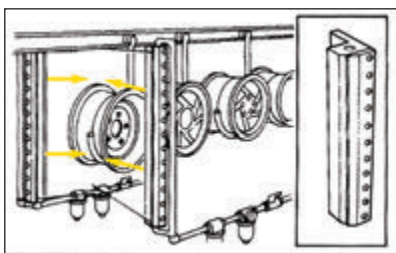

Powder Coating and Curing
Two Model A85024 600mm Air Curtains cool wheel rims as they exit powder coating ovens.

DIMENSIONS:

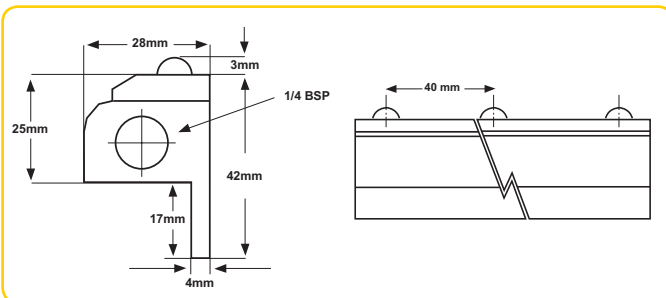

How it works:

The Air Curtain releases a small volume of compressed air through a .002" (.0508mm) slot along its entire length. The 'blade' of air travels down the front face of the Air Curtain creating an area of low pressure behind it that entrains ambient air at a ratio of up to 25:1, delivering a massive airflow to the target.

FEATURES AND BENEFITS:

- | | | |
|-------------------|---|-----------------------------|
| Innovative design | - | 25:1 air amplification |
| | - | Up to 50dBA noise reduction |
| | - | Health and Safety compliant |
| No moving parts | - | Low maintenance |
| Adjustability | - | Application specific set-up |
| Flange | - | Ease of mounting |

PRODUCT NUMBERS AND DESCRIPTIONS:

Aluminium			Aluminium		
A85003	-	80mm Air Curtain	A85030	-	750mm Air Curtain
A85006	-	150mm Air Curtain	A85036	-	900mm Air Curtain
A85012	-	300mm Air Curtain	A85048	-	1200mm Air Curtain
A85018	-	450mm Air Curtain	A85055	-	1400mm Air Curtain
A85024	-	600mm Air Curtain	A85071	-	1800mm Air Curtain

Any length between 50mm and 2000mm can be manufactured to order. Hard Anodised and Stainless Steel units are available on request.



MEECH 300mm AIR CURTAIN:

Inlet Air Pressure		Air Consumption		Sound Level	Thrust Level
psi	bar	cfm	lpm	dBa	Grams
20	1.4	26	736	52	91
40	2.7	37	1048	62	209
60	4.1	45	1274	69	379
80	5.4	52	1473	74	572
100	6.8	58	1643	77	753

300mm PIPE WITH 11x2mm DIA HOLE (25mm Spacing):

Inlet Air Pressure		Air Consumption		Sound Level	Thrust Level
psi	bar	cfm	lpm	dBa	Grams
20	1.4	51	1444	71	193
40	2.7	72	2039	75	415
60	4.1	88	2492	76	669
80	5.4	102	2889	80	972
100	6.8	114	3228	82	1049

PERFORMANCE GRAPH:

Air Curtain (300mm) 'vs' Pipe with 11 x 2mm holes (300mm)

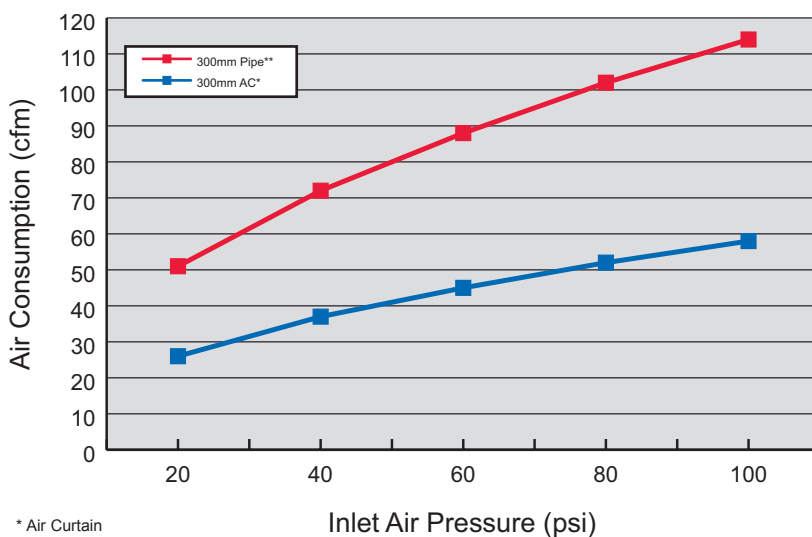

Energy Saving Example

Company 'E' uses a home made 300mm length of pipe with 11 x 2mm holes drilled along its length at 25mm intervals to blow swarf from routed MDF panels. The home made length of pipe runs constantly for 24 hours per day, 5 days per week, 48 weeks per year. The electricity cost for Company 'E' is 5p/kWhr.

The home made length of pipe has an air consumption of 102cfm at 80psi inlet air pressure.

A 300mm Meech Air Curtain running at 80psi inlet air pressure consumes 52cfm (a 51% reduction).

RUNNING COST COMPARISON:

Duration	300mm Air Curtain	300mm Home Made Pipe
Per Day	£11.70	£22.95
Per Week	£58.50	£114.75
Per Year	£2,808	£5,508

Company 'E' can not only achieve a 51% saving in annual running costs (equivalent to £5,508 - £2,808 = £2,700), but also benefits from the consistent blade of air the Air Curtain produces compared to the 'striped' cleaning effect of the home made pipe.





Vortex Tube

Meech Air Technology Stainless Steel Vortex Tubes convert compressed air into two airflows, one extremely cold and the other extremely hot. Vortex Tubes have no moving parts and can produce a drop in temperature up to 50°C below the compressed air temperature whilst reaching temperatures up to +110°C and maintain temperatures at +/-0.6°C.

APPLICATIONS:

- Spot cooling
- Weld cooling
- Plastic slitting
- Extrusion cooling
- Foodstuffs cooling

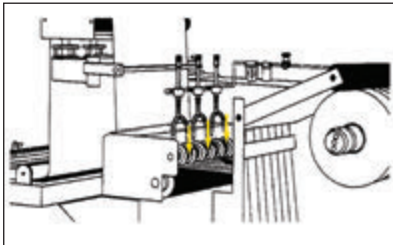

Plastic Slitting

Cutting wheels on this slitter can work at top speed - and stay sharper longer - when cold air from Vortex Tubes eliminates the frictional heat build up. Trim edge is cleaner too.

DIMENSIONS:

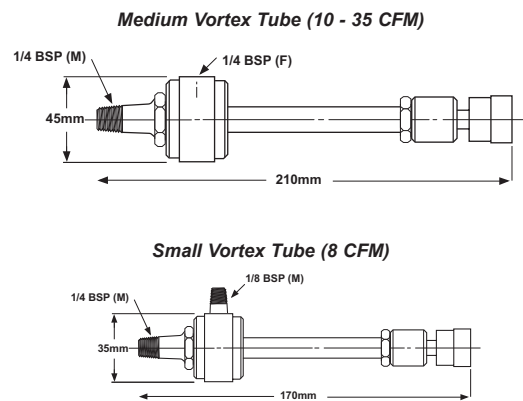

FEATURES AND BENEFITS:

- | | |
|-------------------|--------------------------------|
| Innovative design | - Cold air to -60°C |
| | - Hot air to +110°C |
| Stainless Steel | - Hard wearing |
| No moving parts | - Maintenance free |
| Relief valve | - Accurate temperature control |

PRODUCT NUMBERS AND DESCRIPTIONS:

High Cold Fraction:

- A20008 -
- A20010 -
- A20015 -
- A20025 -
- A20035 -

Low Cold Fraction:

- A21008 - 8cfm, 550BTUH, Small Vortex Tube
- A24011 - 10cfm, 650BTUH, Medium Vortex Tube
- A24016 - 15cfm, 1000BTUH, Medium Vortex Tube
- A24026 - 25cfm, 1700BTUH, Medium Vortex Tube
- A24036 - 35cfm, 2400BTUH, Medium Vortex Tube

Experimental Kits (High and Low Cold Fraction):

- A20300 - 8cfm, 550BTUH, Experimental Kit, Small
- A20400 - 10-35cfm, 650-2400BTUH, Experimental Kit, Medium



HOW A VORTEX TUBE WORKS:

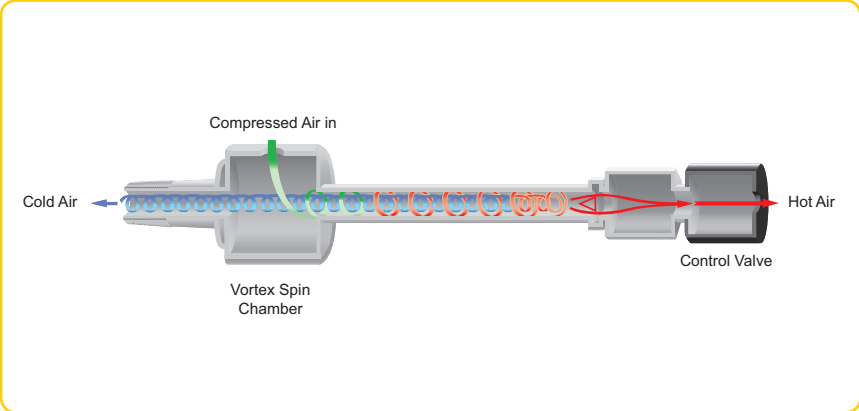

Compressed air enters the spin chamber tangentially. This causes the column of air inside the tube to rotate at a very high speed (up to 1 million rpm). The air at the outside of the column, moving very fast, has a lot of energy and is hot. The air at the centre of the column, moving relatively slowly, has little energy and is cold. The hot outer air, is bled off at one end of the tube and the cold inner air at the other. The percentage of the air exiting the cold end is called the cold fraction and is adjustable by a valve.

Generators:

The generator controls the air consumption of the Vortex Tube and influences the achievable temperatures. Ten generator sizes are available, in total offering five air consumptions - 8, 10, 15, 25 and 35cfm (226, 283, 425, 708 and 991 lpm). For each generator size there is a high and low cold fraction model.



PERFORMANCE GRAPH:

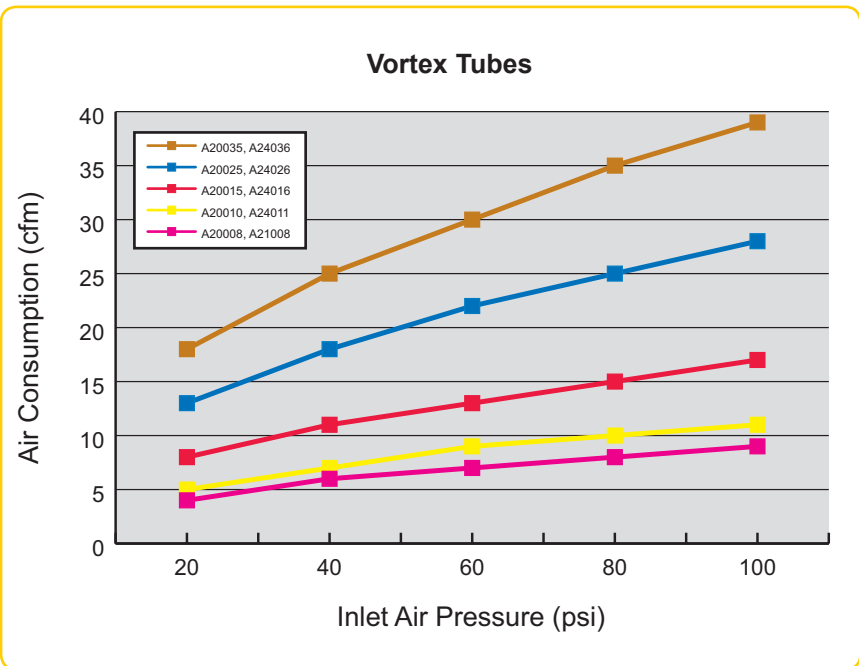

Cold Fraction

The 'cold fraction' is the percentage of input compressed air that is released through the cold end of the Vortex Tube. The cold fraction is adjusted in two ways - by adjusting the control relief valve to exhaust more or less hot air or by changing the generator inside the Vortex Tube to either a 'high' or 'low' cold fraction model.

A 'high' cold fraction is above 50%. This is the setting which best suits most industrial applications as it provides the most efficient cooling, although this is not the coldest possible temperature. A 'low' cold fraction is below 50%. This setting provides a lower cold airflow and allows the coldest temperatures to be achieved. The chart below details the temperature changes that are achievable at various cold fraction settings and inlet compressed air pressures.

VORTEX TUBE PERFORMANCE CHART:

Inlet Air Pressure		Cold Fraction							
psi	bar	20%	30%	40%	50%	60%	70%	80%	
14.7	1	25	24	24	20	18	15	11	
		6	10	15	20	26	33	43	
29.4	2	35	34	32	29	25	21	15	
		8	14	21	29	37	47	59	
44.1	3	53	51	48	44	38	31	23	
		12	21	31	43	55	71	87	
58.8	4	56	54	50	45	39	32	24	
		13	22	31	43	56	71	90	
73.5	5	58	55	51	46	40	33	25	
		13	22	32	43	58	72	91	
88.2	6	59	57	53	48	41	34	26	
		13	22	32	44	58	73	93	
102.9	7	69	66	62	56	48	40	30	
		14	24	35	49	64	80	105	
117.6	8	70	67	63	57	49	41	32	
		14	25	37	51	66	84	105	

Figures in blue detail the achievable temperature drop in °C
 Figures in red detail the achievable temperature rise in °C

Vortex Tubes are factory calibrated to a cold fraction of 70%. This can be achieved by adjusting the control relief valve by approximately 2.5 turns from fully closed.



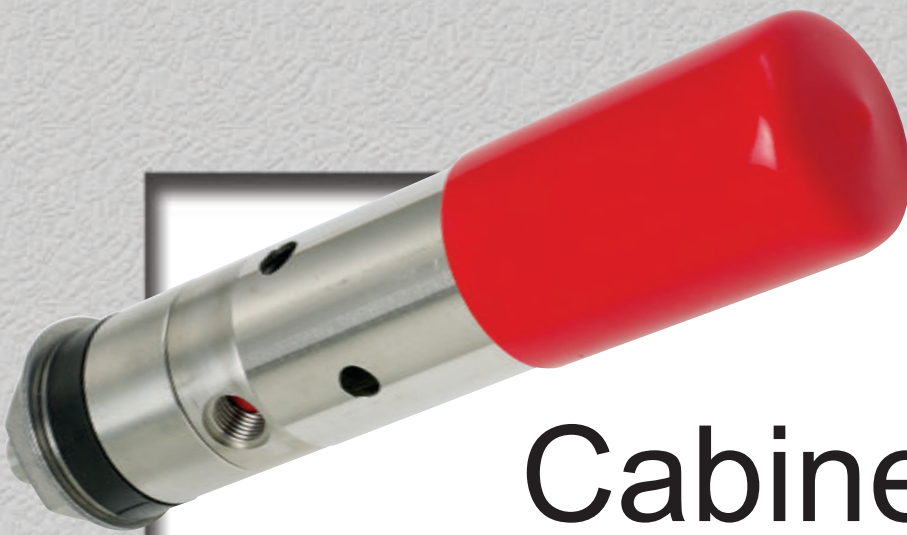

Cabinet Cooler

Meech Air Technology Stainless Steel Cabinet Cooler Systems provide a cold air source to stop cabinets overheating and prevent ingress of contamination such as dust or moisture. When compared to fans that are commonly found in cabinets, Meech Cabinet Cooling Systems provide the ideal cooling solution.

APPLICATIONS:

- Industrial PC cooling
- CCTV camera cooling
- Preventing moisture ingress
- Preventing dust ingress
- Machine control panel cooling
- Product chilling cabinets

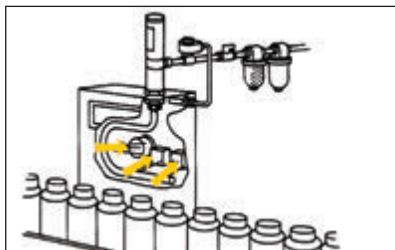

Bottling Plant

Meech Stainless Steel Control Cooling Systems allow easy washdown of these leak testing and production control cabinets in a bottling operation. IP cabinets can be sealed without concern for heat build up.

DIMENSIONS:

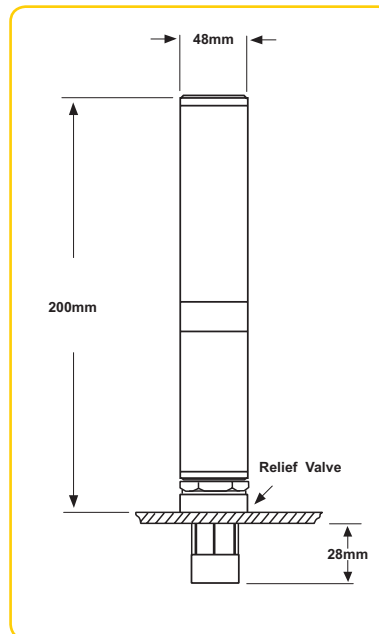

How it works:

The Vortex Tube (see page 18) is at the heart of the Cabinet Cooler. The cold air produced by the vortex tube flows into the cabinet through the bulk head fitting and is then ducted to a known problem component or the centre of the cabinet. The hot air created by the opposite end of the vortex tube flows to atmosphere via a silencer.

FEATURES AND BENEFITS:

- No moving parts - Low maintenance
- Stainless Steel - Suitable for harsh environments
- Pressure relief valve - Prevents cabinet over pressurising
- Digital thermostat and solenoid valve - Maximum efficiency

PRODUCT NUMBERS AND DESCRIPTIONS:

A70025	-	10-35cfm, Cabinet Cooler Unit
A70325-24V	-	10-35cfm, 24V, Cabinet Cooler System
A70325-240V	-	10-35cfm, 240V, Cabinet Cooler System
A70325-110V	-	10-35cfm, 110V, Cabinet Cooler System



CALCULATING YOUR CABINET COOLER:

Meech Cabinet Coolers are supplied with a set of four 'generators' allowing an efficient set up to be achieved (see sizing guide). The generators can easily be changed and are listed in the table below. The red generator is factory fitted as standard.



Sizing Guide

All Meech Cabinet Coolers are capable of cooling up to 2400 Btu/hr 703 Watts. However, optimising efficiency is still a vitally important factor. The following guide shows how to calculate which generator should be fitted in a Cabinet Cooler for it to be most efficient.

Generator	Air Consumption		Cooling Capacity	
	cfm	lpm	W	Btu/hr
Yellow	10	283	190	650
Red	15	425	293	1000
Blue	25	708	499	1700
Brown	35	991	703	2400

To allow the most efficient generator to be selected you must calculate the total heat load in Btu/hr or Watts to which the cabinet is exposed. The total heat load is a combination of the heat transfer from outside due to the ambient air temperature into the cabinet and the heat which is created internally.

Calculating which Generator:

1. Calculate the heat load created inside the cabinet. Remember that equipment inside the cabinet will have an efficiency level; for example a 2kW inverter drive that has a 95% efficiency will dissipate 100 watts (Watts x 3.41 = Btu/hr).

2. To calculate the heat load due to the ambient air temperature outside the cabinet you need to:

a) Calculate the area of the cabinet that is exposed to ambient air in square metres.

b) Calculate the temperature difference between the maximum surrounding ambient air and the desired internal temperature. For example; maximum ambient temp = 35°C, desired internal temp = 25°C therefore the

temp difference = 10°C (35°C - 25°C).

c) Using the conversion table below select the appropriate heat load per m2 figure.

Temperature Difference °C	W/m ²	Btu/hr/m ²
5	9.2	31.3
10	19.7	67.3
15	31.6	107.8
20	44.9	153.0
25	59.4	202.6
30	75.3	256.9

d) Calculate the heat load in the cabinet due to the external ambient temperature using the following formula:

External Heat Load = Temperature Difference (°C) x Exposed Cabinet Area (m²) x Heat Load per m² (Btu/hr/m² or W/ m²).

3. Add the internal heat load (1) to the external heat load (2) to give the total heat load.

Sizing Guide Example:

A cabinet has an internal heat dissipation of 200 Watts. The desired internal temperature is 25°C. The ambient temperature outside the cabinet is 35°C. The cabinet has a surface area of 2.5m² exposed to the ambient air.

For a temperature difference of 10°C (35°C - 25°C) the conversion table gives you an external heat load of 19.7W/m². Therefore for 2.5m² exposed surface the heat load on the cabinet is 2.5m² x 19.7W/m² = 49.25W. Adding the internal heat dissipation of 200W gives us a total heat load of 249.25W. This is achievable using the red generator.

Cabinet Cooler Systems

Meech Cabinet Cooling Systems comprise a cabinet cooler unit, set of four generators, ducting hose, solenoid valve and digital thermostat control.

The combination of solenoid valve and digital thermostat allows application specific set-up and minimises running costs of the system.



The digital thermostat (pictured) is suitable for panel mounting and provides a constant display of the temperature inside the cabinet. The 'on' and 'off' temperature set points of the thermostat can be adjusted so that the cabinet cooler can be set to run only when required.

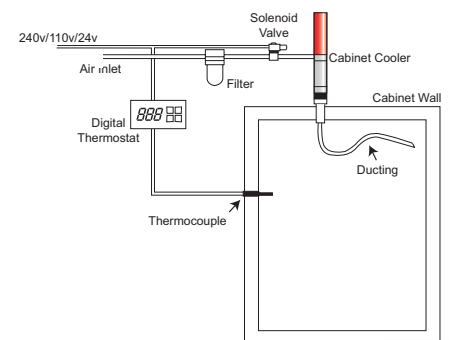

For example, if the cabinet overheats when its internal temperature reaches 32°C the digital thermostat can be set to turn the cabinet cooler on when the internal temperature reaches 29°C and off once it has cooled down to 25°C. This minimises running costs and gives peace of mind that the cabinet will not overheat.

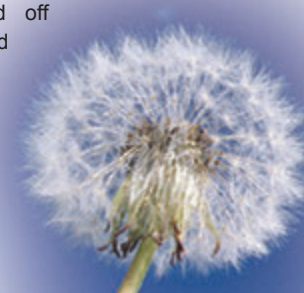

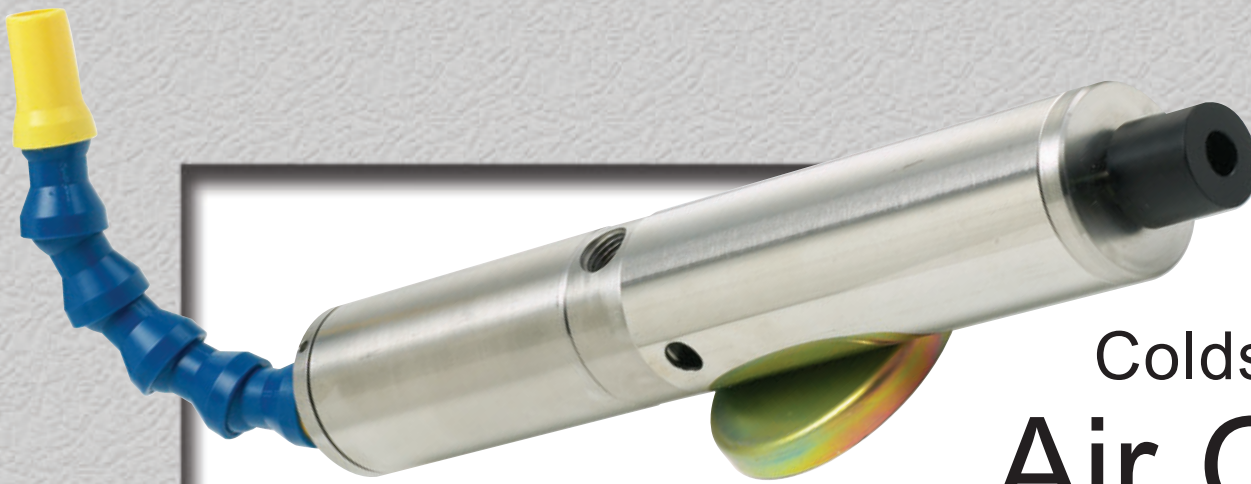

Coldstream Air Gun

Coldstream Air Guns from Meech Air Technology provide a cold airflow that is commonly used for spot cooling. The cold airflow can be up to 50°C below the compressed air temperature and be maintained to +/- 0.6°C.

APPLICATIONS:

- *Weld seam cooling*
- *Woodworking routing*
- *Cooling foodstuffs*
- *Metalworking: grinding*
- *Plastics machining*
- *Textiles: sewing*

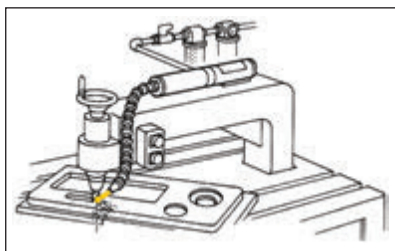

Woodworking - Routing

For faster routing, without burning and discolouring the wood, the Coldstream Gun directs air at -12°C on to the router bit, leaving no residue.

DIMENSIONS:

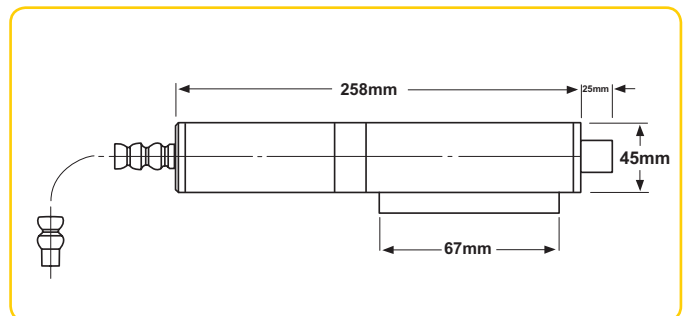

How it works:

The Vortex Tube (see page 18) is at the heart of the Coldstream Air Gun encased within hot and cold end silencers. The cold air produced by the vortex tube is easily directed on to the area to be cooled by use of the knuckle trunking, whilst the hot air created by the opposite end of the vortex tube flows to atmosphere via a silencer.

FEATURES AND BENEFITS:

- | | |
|-----------------------|-----------------------------------|
| No moving parts | - Low maintenance |
| Stainless Steel | - Suitable for harsh environments |
| Adjustment knob* | - Accurate temperature control |
| 28cm knuckle trunking | - Easy direction of cold airflow |
| Magnetic base | - Quick and easy mounting |

*adjustable models only

PRODUCT NUMBERS AND DESCRIPTIONS:

A60015A	-	Large Adjustable Coldstream Air Gun, Single ½" outlet
A60015	-	Large Non Adjustable Coldstream Air Gun, Single ½" outlet
A60015AY	-	Large Adjustable Coldstream Air Gun, Double ½" outlet
A60015Y	-	Large Non Adjustable Coldstream Air Gun, Double ½" outlet
A60008	-	Small Non Adjustable Coldstream Air Gun, Single ¼" outlet



YELLOW GENERATOR:

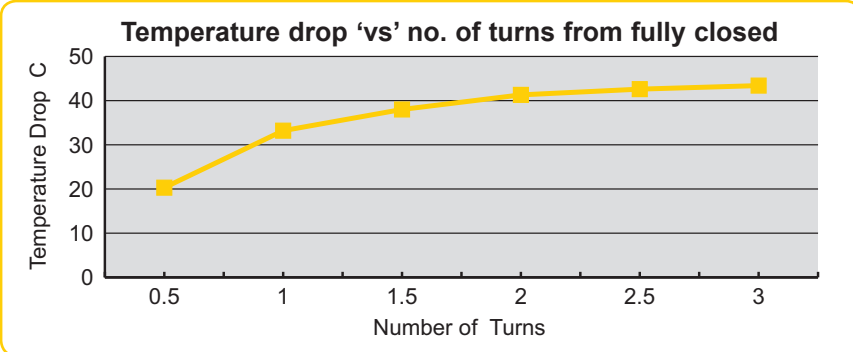

RED GENERATOR:

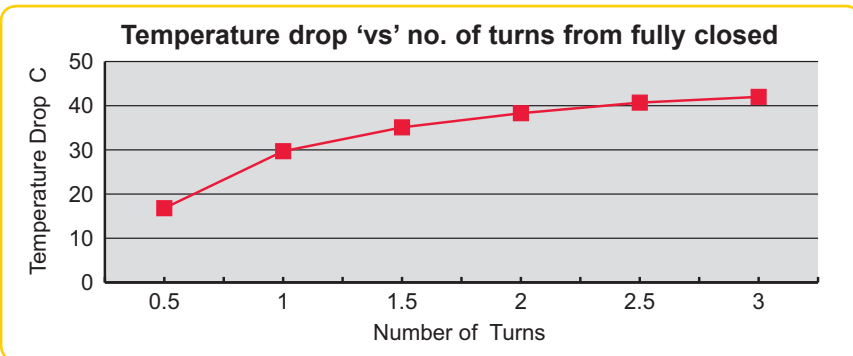

BLUE GENERATOR:

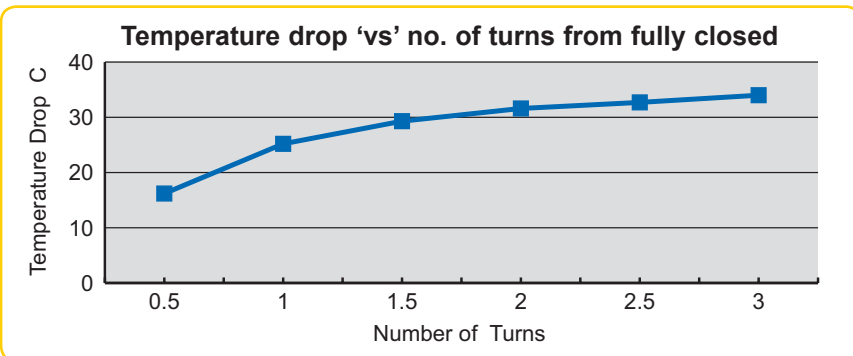

BROWN GENERATOR:

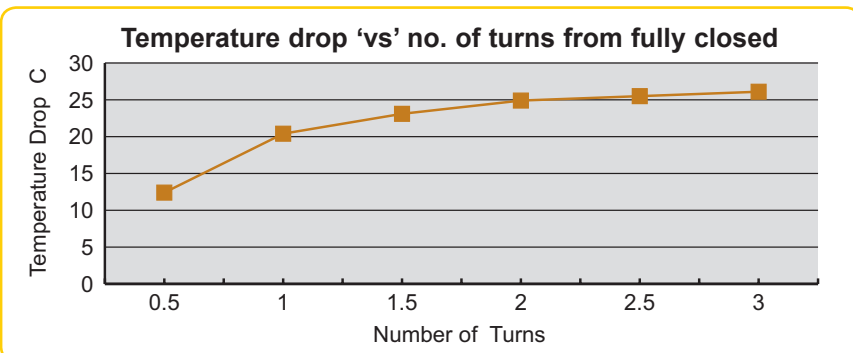

Temperature Drop

The graphs (left) detail the temperature drops in °C that are achievable from the inlet air temperature supplied to the Coldstream Air Gun. For each 'generator' temperature drops are shown with the adjustment knob set at 0.5, 1, 1.5, 2, 2.5 and 3 turns from fully closed at 80 psi inlet air pressure.

Generator	Air Consumption		Cooling Capacity	
	cfm	lpm	W	Btu/hr
Yellow	10	283	190	650
Red	15	425	293	1000
Blue	25	708	499	1700
Brown	35	991	703	2400

All Coldstream Air Guns are supplied with 10, 15, 25 and 35cfm (yellow, red, blue and brown) generators.



The generator controls the air consumption of the coldstream air gun and influences the temperature drop that is achievable.

The 15cfm red generator is factory fitted and the coldstream air gun is calibrated with the adjustment knob open 2.5 turns from fully closed.





All you need, from the best in the business

Meech is also a leading provider of:

- **Industrial Static Control Systems** – Eliminating unwanted static or creating a controlled static charge in industrial processes can increase productivity, reduce waste and enhance quality.
- **Web Cleaning Systems** – Typically used within the printing and packaging industries to remove contamination, improve print quality and increase productivity.
- **JetStream Air Knife Systems** – Energy efficient air knife systems that are used for contamination and surface moisture removal.
- **ESD** – High sensitivity static control for electronic cleanroom environments to prevent ESD damage and reduce failure rates.

Meech International (UK)

2 Network Point
Range Road, Witney
OX29 0YN, UK

Tel: +44 (0)1993 706700
Fax: +44 (0)1993 776977
email: sales@meech.com

Meech International (USA)

2915 Newpark Drive
Norton, OH 44203
USA

Tel: +1 330 564 2000 / 1 800 232 4210
Fax: +1 330 564 2005
email: info@meech.com

Meech International (Belgium)

Kaiserbaracke 66
B-4780 St.Vith
Belgium

Tel: +32 8086 2983
Fax: +32 8086 2821
email: mesa@meech.com

Meech International (Hungary)

2151 Fót
Széchenyi út. 46
Hungary

Tel: +36 27535075
Fax: +36 27535076
email: ce@meech.com

Meech International (China)

Room 205, Huana Hotel Office Tower
No. 1733 Lianhua Road
Shanghai 201103
China

Tel: +86 400 820 0102
Fax: +86 400 820 0102*201
email: china@meech.com